

• **VB-FullAir-4C**
Technical specifications

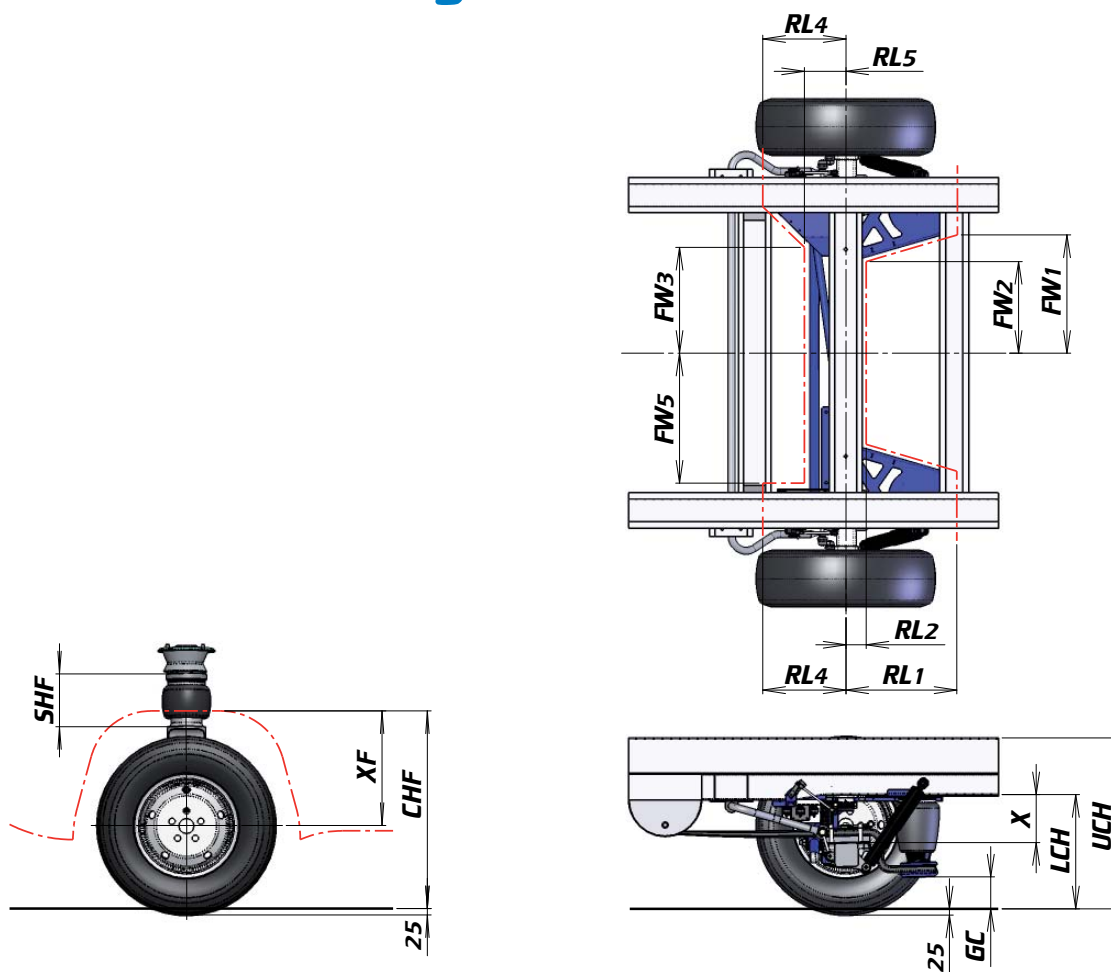

Peugeot Boxer X-250



Description*	Lowest position	Ride-height	Highest position
Lower chassis height (LCH)	380	445	490
Upper chassis height (UCH)	610	675	720
Ground clearance (GC)	135	115	107
X-value (X) **	140	205	250
X-value front axle (XF)	370	465	535
Chassis height front axle (CHF)	690	785	855
Air-spring height (SHF)	125	210	270
Rear length (RL1 / RL2 / RL4 / RL5)	480 / 60 / 330 / 165		
Frame width (FW1 / FW2 / FW3 / FW5)	450 / 345 / 420 / 515		

* All the measurements are in mm, measured above the centre-line of the axles on a standard chassis, with tyre size 225/70R15, a rear axle load of 1920kg and a front axle load of 1650kg. Therefore a tyre compression of 25mm is included.

** The X-value is the measure between the rear axle and the underside of the cross beam, in the middle of the vehicle

Peugeot Boxer X-250

Technical specifications

Air-suspension system

Suspension system contains mainsprings (trailing arms) with air-springs and shock absorbers. The system has a separated-air-circuit with four height sensors.

The electronics of the air suspension is tested according to EMC (European directives for electronics) directive 72/245/EEC last amended, 2006/28/EC.

The air-suspension can be controlled by the supplied remote control: VB-FORC (Full Option Remote Control). It's even possible to control the system through the electrical system or CAN-bus system of the body builder. For more information, contact VB-Airsuspension.

Weights

The weight change of the vehicle after switching to air-suspension depends of the kind of leaf springs removed.

For leaf spring C435 CT2353: +43kg

For leaf spring C453 CT351: +57kg

Raise- and lowertimes

The raise and lower times depends on the load of the vehicle. The measured values are measured by a rear axle load of 1920kg and a front axle load of 1650kg.

Raise time lowest position > ride height: 91 sec

Raise time ride height > highest position: 105 sec

Lower time highest position > ride height: 44 sec

Lower time ride height > lowest position: 54 sec

Compressor

Contains an air dryer, thermal circuit breaker and a pressure protection valve.

Operating voltage: 12V

Nominal current: 26A

Starting current: $\leq 120A$ over $t \leq 100ms$

Degree of protection : IP68

Maximum pressure: 10-13 bar

Air-spring

VB-TS (Tapered Sleeve) with double polyamide cord ply and extra low resistance and hysteresis. This air-spring is specially developed for use with light commercial vehicles.

Shock absorber

Adjustable, double-acting shock absorber.

Options

- Rear-door switch kit
- Extra-time module
- VB-AutoLevel (Leveling function)
- VB-AOWS (Axle Overloading Warning System)

Notes

For the fitting of the air-suspension kit the factory option JI18 is required.

By fitting the air-suspension kit, the maximum GVW or the maximum axle load is not altered.

There is also an air-suspension kit available for vehicles with ALKO chassis. For more information, please contact VB-Airsuspension.

The measured weights are approximately determined.

