

• *VB-FullAir-2C*

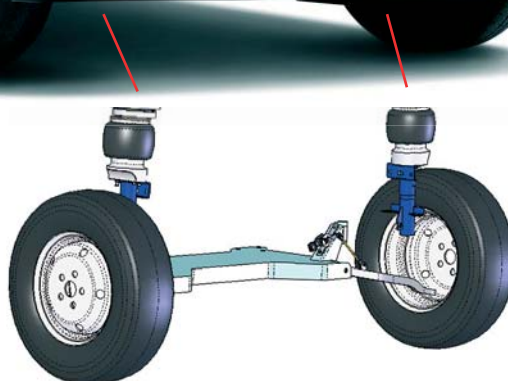

## *Fiat Ducato X250 with front axle airsuspension*



**!!!!!! NEW !!!!!**  
**VB-FullAir-2C**  
**airsuspension**  
**for the front axle**

# Fiat Ducato X250

## with VB-FullAir-2C front axle airsuspension

Airsuspension systems for camping cars and other light commercial vehicles have become a commonly specified option in recent years. Now Fiat Ducato have his own solution for the front-axle, developed by VB-Airsuspension in Holland, in the form of an integrated front axle 2-Corner airsuspension system.

This newly developed and innovative front axle air suspension, from VB-Airsuspension, is available as an after-market option through the VB-Airsuspension dealers and the Fiat network.

After successfully completing all the different tests, the VB-FullAir-2C air suspension for the front axle option has become available.

The PFC-X250 like the Fiat Ducato is extremely suited for the use of air suspension systems and our VB-FullAir-2C air suspension is available for new and used vehicles.



### VB-FullAir 2C system

The VB-FullAir-2C, a full-air front-axle air-suspension, has an electronic system named VB-ASCU (VB-Air Suspension Control Unit), which automatically monitors and adjusts the Ride-height of the vehicle. This constant monitoring and adjusting, in the longitudinal and lateral direction, will automatically contribute to a safe vehicle behaviour and improved comfort on the front axle.

### Advantages VB-FullAir-2C for the front axle:

- Improved suspension comfort
- Constant ride height
- Improved road handling and stability
- Increased protection of vulnerable / sensitive goods
- Less impact for passengers
- Less wear of tyres / brakes
- Environmentally friendlier, less CO2 emission

### Changing height

The vehicle level can be changed manually with the standard handheld remote-control when the vehicle stands still; therefore lowering of the chassis/ load platform is one of the systems standard possibilities.



### Supply and service

The air-suspension for the Ducato can be supplied and serviced by VB-Airsuspension dealers and the PFC dealer organisation.

### Better comfort

The air-suspension system more or less filters the unevenness of the road so the passengers are subjected to less energy (vibrations). This increases comfort and reduces fatigue. That is why more and more car manufacturers equip their vehicles with air-suspension.



Technical specifications:*	VB-FullAir-2C frontaxle
Standard ride-height <i>(Unloaded with original steel suspension)</i>	435 mm
Ride height with VB-FullAir-2C	465 mm
Highest position	+70 mm
Lowest position	-95 mm

Heights are measured from wheel arch to wheel centre.

\* possible tolerance in measurements reserved.

For more information: [info@vbairsuspension.com](mailto:info@vbairsuspension.com)



© 01-2010